

**ASSIGNMENT BOOKLET**  
**Bachelor's Degree Programme (B.Sc.)**

**ELECTRICAL CIRCUITS AND ELECTRONICS**

**Valid from January 1, 2026 to December 31, 2026**

**It is compulsory to submit the Assignment before filling in the  
Term-End Examination Form.**

**Please Note**

- You can take electives (56 to 64 credits) from a minimum of TWO and a maximum of FOUR science disciplines, viz. Physics, Chemistry, Life Sciences and Mathematics.
- You can opt for elective courses worth a MINIMUM OF 8 CREDITS and a MAXIMUM OF 48 CREDITS from any of these four disciplines.
- At least 25% of the total credits that you register for in the elective courses from Life Sciences, Chemistry and Physics disciplines must be from the laboratory courses. For example, if you opt for a total of 64 credits of electives in these 3 disciplines, at least 16 credits should be from lab courses.
- You cannot appear in the Term-End Examination of any course without registering for the course. Otherwise, your result will not be declared and the onus will be on you.



**School of Sciences**  
**Indira Gandhi National Open University**  
**Maidan Garhi, New Delhi-110068**

**(2026)**

Dear Student,

We hope you are familiar with the system of evaluation to be followed for the Bachelor's Degree Programme. At this stage you may probably like to re-read the section on assignments in the Programme Guide for Elective Courses that we sent you after your enrolment. A weightage of 30 per cent, as you are aware, has been earmarked for continuous evaluation which would consist of one tutor-marked assignment (TMA) for this course. Submit your assignment response at your Study Centre.

### Instructions for Formatting Your Assignments

Before attempting the assignment please read the following instructions carefully:

- 1) On top of the first page of your **TMA** answer sheet, please write the details exactly in the following format:

---

ENROLMENT NO. : .....

NAME : .....

ADDRESS : .....

.....

.....

COURSE CODE : .....

COURSE TITLE : .....

ASSIGNMENT NO. : .....

STUDY CENTRE : ..... DATE : .....

---

**PLEASE FOLLOW THE ABOVE FORMAT STRICTLY TO FACILITATE EVALUATION AND TO AVOID DELAY.**

- 2) Use only foolscap size writing paper (but not of very thin variety) for writing your answers.
- 3) Leave 4 cm margin on the left, top and bottom of your answer sheet.
- 4) Your answers should be precise and in your own words. Do not copy answers from study material.
- 5) While solving problems, clearly indicate the question number along with the part being solved. Write units at each step of your calculations as done in the text because marks will be deducted for such mistakes. Take care of significant digits in your work. Recheck your work before submitting it.
- 6) **This assignment will remain valid from January 1, 2026 to December 31, 2026.** However, you are advised to submit it within **12 weeks** of receiving this booklet to accomplish its purpose as a teaching-tool.

Answer sheets received after the due date shall not be accepted.

**We strongly feel that you should retain a copy of your assignment response to avoid any unforeseen situation and append, if possible, a photocopy of this booklet with your response.**

You could obtain response to the difficulties you may face in PHE-10 course via e-mail by writing to [sgokhale@ignou.ac.in](mailto:sgokhale@ignou.ac.in). Please note that, we do not provide answers to Assignment questions.

We wish you good luck.

## Tutor Marked Assignment PHE-10: Electrical Circuits and Electronics

Course Code: PHE-10  
Assignment Code: PHE-10/TMA/2026  
Max. Marks: 100

**Note:** Attempt all questions. Symbols have their usual meanings. The marks for each question are indicated against it.

---

1. State, **with reasons**, whether the following statements are True or False. (2×10)
- i) Thevenin's theorem is valid only for resistive networks.
  - ii) Impedance matching is the necessary condition for proper operation of any electronic system.
  - iii) In practical rectifier circuit, the peak amplitude of the output voltage is always smaller than the input peak amplitude.
  - iv) If the gain of an amplifier is 50 dB, its mid band gain equals 25 dB.
  - v) By using positive feedback, the gain of an amplifier can be stabilized.
  - vi) CMRR of an op-amp determines its highest operating frequency.
  - vii) 79XX series voltage regulator IC cannot provide output current more than 10 mA.
  - viii) Only the decimal numbers divisible by 8 can be represented by octal system.
  - ix) Truth table of a 3-input OR gate is same as that of a 3-input NAND gate.
  - x) X and Y inputs of CRO can be used to directly measure the current flowing through a given circuit.
2. Using superposition principle obtain the voltage across the load resistance  $R_L$  and the current flowing through it in the circuit given in Fig. 1. (8+2)

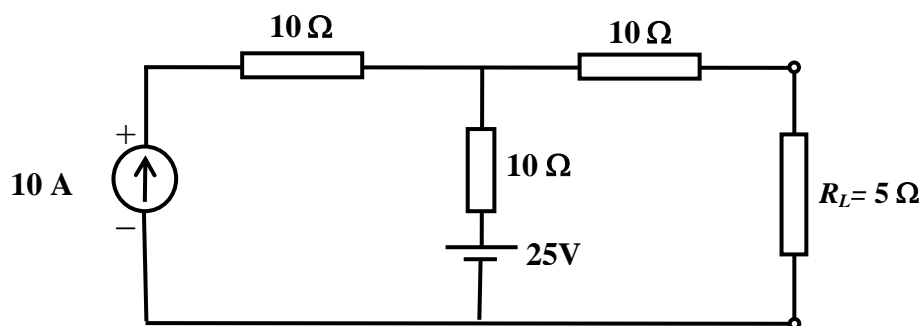

Fig. 1

3. a) Explain the statement “Transistor is a current controlled device while FET is a voltage controlled device”. (5)

- b) Calculate the resonance frequency, bandwidth and  $Q$ -factor of the circuit shown in Fig. 2. (5)

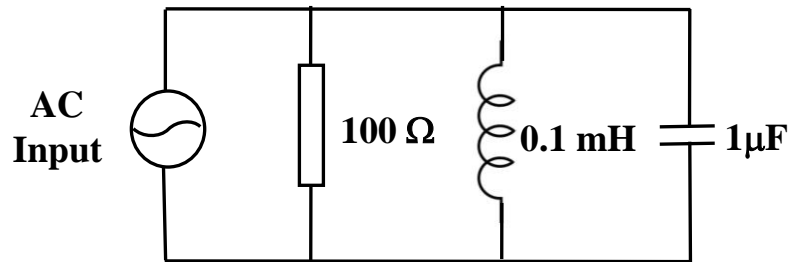

Fig. 2

4. a) In the universal biasing of a transistor, which resistor acts as a feedback element? How does it provide stability to the circuit? (1+4)
- b) Explain, how class B amplifier is more efficient than class A amplifier. What will be the effect on the output of a push-pull amplifier if unmatched transistors are used? (2+3)
5. a) Why LC oscillators are preferred over RC oscillators to generate high frequencies? Why 2-stage amplifier is required in Wein bridge oscillator in contrast to a single stage amplifier in the phase shift oscillator? (3+2)
- b) Design and draw a zener voltage regulator to provide 5V output if load resistance varies between  $100\ \Omega$  and  $500\ \Omega$ . Assume that the input unregulated dc voltage is 6V. (5)
6. Compare the operational amplifier with a class A common emitter amplifier on the basis of gain, bandwidth, input-output phase relationship, input impedance and output impedance. (10)
7. a) Draw the output waveform indicating proper scales on the time and voltage axes for the given input waveform to the circuit shown in Fig. 3. (5)

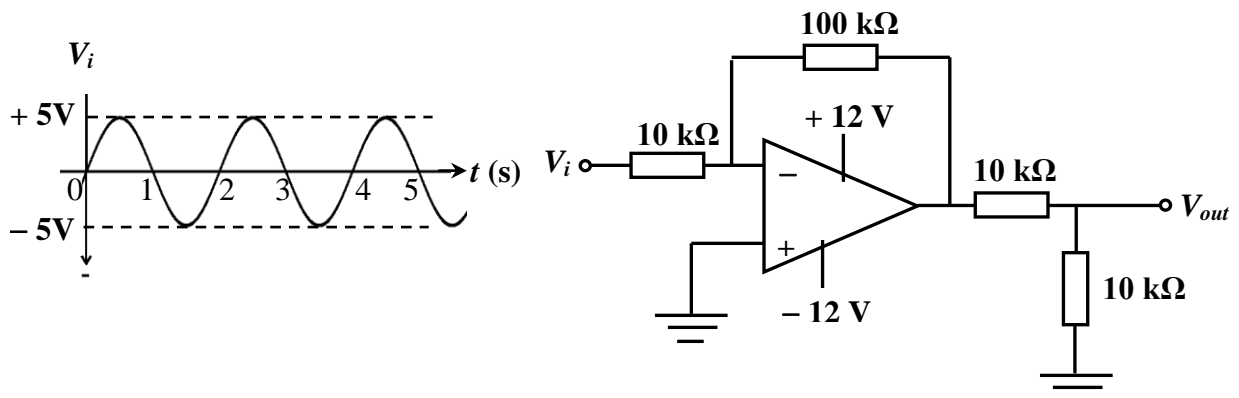

Fig. 3

- b) Design and draw voltage regulator to provide 2 to 10V variable output voltage using IC 7812. (5)

8. a) Divide 0001010001001001 (BCD) by  $1001_2$  and express the result in octal equivalent. (5)
- b) Find the MSP expression for following relation and draw its logic gate implementation with minimum number of gates.
- $$Y = A\bar{C} + AC(B + \bar{C}) \quad (5)$$
9. a) Explain the working of synchronous counter. (5)
- b) Discuss the use of signal generator circuits in the functioning of a CRO. (5)

\*\*\*\*\*